

WAAS CH 86637 W27A	APP CRS 269°	Rwy Ldg TDZE Apt Elev	3098 465 465
--	------------------------	-----------------------------	---

RNAV (GPS) RWY 27

BRANDYWINE RGNL (OQN)

RNP APCH - GPS.	<p>⚠ Rwy 27 helicopter visibility reduction below $\frac{3}{4}$ SM NA. When local altimeter setting not received, use Coatesville altimeter setting and increase all MDAs 60 feet.</p>	MISSED APPROACH: Climb to 1500 then climbing right turn to 2900 direct GONVE and hold.
-----------------	--	--

AWOS-3T 121.4	PHILADELPHIA APP CON 124.35 319.15	CLNC DEL 125.6	UNICOM 123.075 (CTAF)
-------------------------	--	--------------------------	---------------------------------

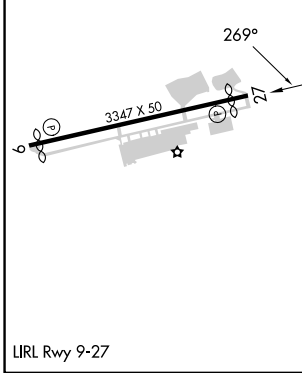
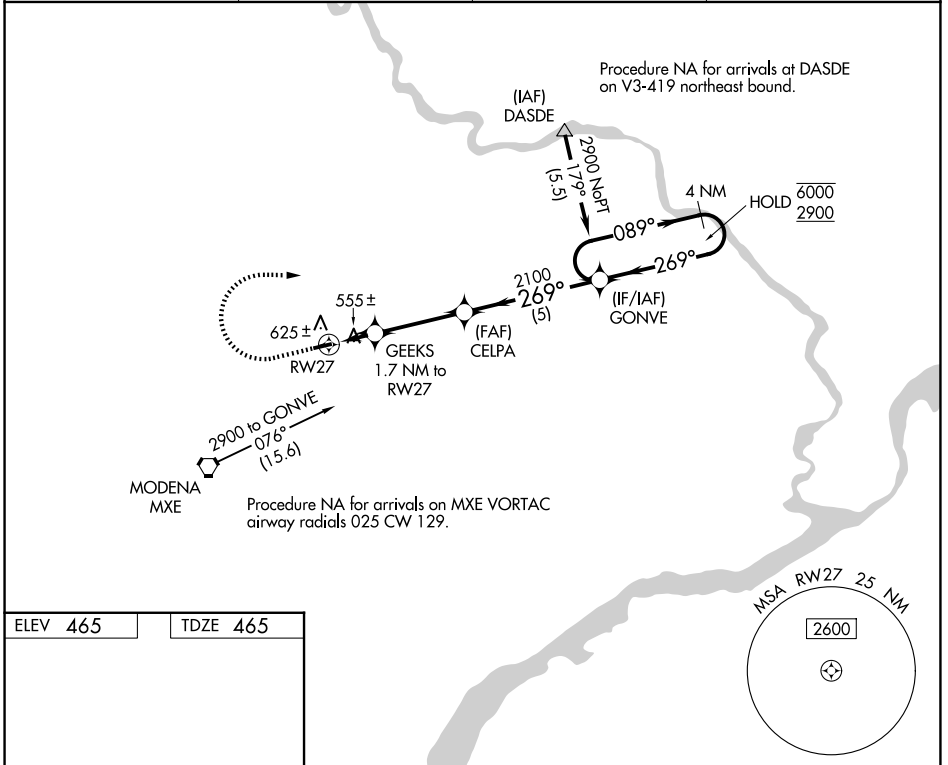

ELEV 465	TDZE 465	<p>1500 2900 GONVE</p> <p>VGSI and descent angles not coincident (VGSI Angle 3.00/TCH 20).</p>		
		<p>GONVE 4 NM Holding Pattern</p>		
<p>1.1 NM to RWY 27</p> <p>0.6 NM</p> <p>3.3 NM</p> <p>5 NM</p>		<p>CELPA</p> <p>GEEKS 1.7 NM to RWY 27</p> <p>2100</p> <p>1040</p> <p>3.00° TCH 45</p> <p>269°</p> <p>089°</p> <p>6000</p> <p>2900</p>		
CATEGORY	A	B	C	D
LP MDA	820-1	355 (400-1)		NA
LNVA MDA	860-1	395 (400-1)		NA
CIRCLING	1080-1	615 (700-1)		NA

NE-4, 11 JUN 2026 to 09 JUL 2026

NE-4, 11 JUN 2026 to 09 JUL 2026